

## 5MP FISH EYE IP Camera

### Main Feature

- Resolution 5MP
- 6 Smart IR Led
- Support Light sensor-Scene Brightness
- Low consumption, low code stream, low delay
- 1.8mm Ultra Wide Fixed Lens
- Built-in Mic for Audio (Optional)
- Dedicated PoE PCB



Feature	Specification
Product Name	Fish Eye 5 MP IP Camera
Brand	Ditsvision
Model No.	DVC -R5053 -PFE
Warranty	3 years
Sensor	1/3", 5MP low illumination CMOS sensor
Lens	1.8mm Fixed Fish Eye Lens
Style	Dome
<b>Night &amp; Lights</b>	
Day & Night	ICR switch, auto/color/B&W/ scene trigger
D-WDR	DWDR >80db
Led Control	IR auto/manual
3D DNR	Off/Low/Middle/High/Higher
Mirror	Off/horizontal mirror/vertical mirror/180° flip
Image Setting	Brightness, contrast, sharpness, saturation, chroma
S/N	≥50db (AGC off)
Illumination	Color 2.05Lux@F1.2; B/W 0.005Lux@F1.2,
<b>Lens</b>	
F No.	2.0±10%
Focal Length	1.8mm
Image Circle	Φ6.9 ( Max)
Lens Construction	6E+IR650
Mount	M12*P0.5
Clamp Force	60-600gf -cm
FOV	H132.2° V92.1° D191.2°
Optical Distortion	13%
Relative Illumination	55%
M.O. D	0.2m
Operation	Fixed
Aperture coefficient	F2.0
Image Size	1/3"

Audio & Video Encoding	
Standard	H.265/H.264
Encoding Feature	Main stream: 2880*1616@1 -25fps, 2560*1440@ 30fps, 2304*1296 @30fps, 1920*1080@ 30fps, 1280*720@30fps  Sub-stream: D1(704*576), VGA (640*480), Q720P (640*360), CIF (352*288), QVGA (320*240) @30fps
Max Resolution	5MP 2880 *1616
Video Code Rate	Fixed code rate, variable code rate (main stream:1 28Kbps -8192 kbps)
Video Type	Composited stream/video stream
Audio Standard	G.711u/ G.711A 64Kbps
Subtitle Overlay	Support Channel name, Date & time & 4line of Character overlay
Network Function	
Network protocol	TCP/IP UDP, HTTP, HTTPS, DHCP,
Connection Protocol	Standard Onvif Protocol
Security Mode	Authorized user name and password, HTTPS encryption,
Motion Detection	Set detection area, can set multi -level sensitivity
Privacy Mask Alarm	Support 1 area
Privacy Mask	Support 1 area
Schedule Linkage	Snapshot, email
Ports	
Network Port	RJ45 10M/100M network self -adaptation
Audio	MIC Input/ Output (optional)
Power	Dc 12V inpu
General	
Power Supply	12V PoE (2W)
Working Temperature	-15°C ~ 50°C
Working Humidity	0 ~90
Application Area	Indoor
Packaging	
Unit in a box	1 Pc
Box Dimension	12x9x11cm
Product Weight	200gms
Box weight with Item	250gms

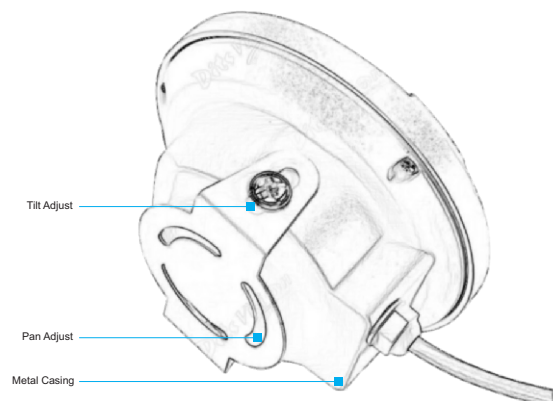
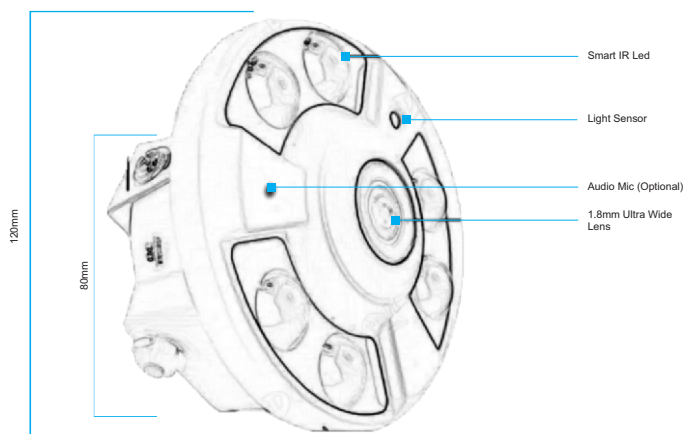

## Duo Sense Series Overview

The Duo Sense Series by Ditsvision represents a breakthrough in CCTV technology, designed to offer unmatched security and surveillance capabilities. This series combines advanced features with cutting-edge technology to deliver superior performance in various monitoring environments.

### Current Offerings:

- **IP Cameras:** The Duo Sense Series currently includes state-of-the-art IP cameras, providing high-resolution video and seamless integration with modern security systems.

### Upcoming Expansion:

- **HD Coaxial Cameras:** In the near future, the Duo Sense Series will expand to include HD Coaxial Cameras, ensuring compatibility with a broader range of existing infrastructures while maintaining high-definition video quality.

### Key Features:

1. **Dual Light Capability:**
  - **Automatic Switching:** The cameras in the Duo Sense Series are equipped with Dual Light Capability, which intelligently switches between color and IR modes based on real-time analysis. When human or human-like objects are detected at night, the camera automatically shifts to color mode, enhancing visibility and detail. If no such objects are present, it reverts to IR mode for efficient, clear night vision.
2. **Enhanced Video Clarity:**
  - **High-Resolution Imaging:** The Duo Sense Series is engineered to deliver the highest video clarity ever seen in Ditsvision products, capturing detailed, high-resolution images and videos to ensure nothing is missed.
3. **High-Quality Audio Clarity:**
  - **Clear Audio Recording:** The series also features advanced audio technology, providing high-quality audio clarity to complement the superior video footage. This ensures comprehensive surveillance and accurate incident analysis.

### Applications:

- **Residential Security:** Ideal for home security, providing peace of mind with its advanced detection and recording capabilities.
- **Commercial Surveillance:** Perfect for businesses seeking reliable and high-quality surveillance to protect assets and personnel.
- **Public Safety:** Suitable for use in public spaces to enhance safety and security through detailed monitoring and recording.

The Duo Sense Series is a testament to Ditsvision's commitment to innovation and excellence in the field of CCTV technology. By combining advanced features with practical functionality, the Duo Sense Series offers a comprehensive solution for all your surveillance needs.

## Company Overview

Ditsvision is a leading company in the field of security and surveillance technology, committed to providing cutting-edge solutions that meet the evolving needs of our customers. With a focus on quality, reliability, and technological advancement, Ditsvision has established itself as a trusted name in the industry.

### Our Mission:

At Ditsvision, our mission is to enhance security and peace of mind for individuals and organizations through state-of-the-art surveillance products and solutions. We strive to deliver superior performance, exceptional value, and unparalleled customer support.

### Our Products:

Ditsvision offers a comprehensive range of security and surveillance products designed to cater to diverse applications:

- **CCTV Cameras:** Our wide array of CCTV cameras includes IP cameras, analog cameras, and the latest in our lineup, the Duo Sense Series. Each product is engineered to provide high-resolution imaging, advanced detection capabilities, and reliable performance.
- **Digital Video Recorders (DVRs):** Our DVR solutions are designed to work seamlessly with our cameras, offering robust recording, playback, and storage capabilities. They are built to ensure data integrity and ease of use, making surveillance management simple and effective.

### Innovation and Quality:

Innovation is at the heart of Ditsvision. Our research and development team continuously works to integrate the latest technologies into our products, ensuring that we stay ahead of the curve. We prioritize quality in every aspect of our manufacturing process, using only the highest-grade materials and rigorous testing standards to ensure the reliability and durability of our products.

### Certifications:

Ditsvision is proud to hold several key certifications that demonstrate our commitment to quality and environmental responsibility, including:

- **ISO 9001:2015:** Quality Management Systems/ISO
- **14001:2015:** Environmental Management Systems
- **CE:** Conformité Européenne, ensuring product compliance with EU regulations
- **RoHS:** Restriction of Hazardous Substances, ensuring products are free from certain hazardous materials

### Customer-Centric Approach:

At Ditsvision, we believe in building lasting relationships with our customers. Our customer-centric approach means we listen to feedback, understand the unique needs of each client, and provide tailored solutions that exceed expectations. Our dedicated support team is always ready to assist with any inquiries or issues, ensuring a seamless experience from purchase to installation and beyond.

**Sustainability:** We are committed to sustainable practices and environmentally friendly manufacturing processes. Ditsvision continually seeks ways to reduce our environmental footprint while maintaining the highest standards of product excellence.

